

# Common CGT-02 MID Turbine Gas Meters



## CGT50 - CGT300

The turbine gas meter measures the quantity of gas basing on the flow principle. The gas flows through an integrated flow conditioner, which distributes the flow proportionally in the annular slot and guides it to the turbine wheel. The wheel is driven by the gas flow, and the angular velocity of the rotation is proportional to the gas flow rate. The rotary motion of the turbine wheel is transferred mechanically by gear wheels, and the incorporated gas tight and hermetic magnetic coupling, to the index unit, mounted on the top of the body, and shows the volume on the totaliser.

The basic components of the COMMON CGT series turbine gas meter are as follows:

- Pressure resistant meter body (1)
- Inlet flow conditioner (2)
- Measuring cartridge with the turbine wheel (3)
- Magnetic coupling as the transferring element between the measuring cartridge and the index head (4)
- Index head, IP67 protection class (5)
- Lubricating system (some meters may be provided)

## At a glance

- Fitted with low frequency pulse output as standard
- Flanged PN16 connection
- Cast Iron or Carbon Steel, suitable for natural gas and LPG -20 to 60C
- Inline turbine gas meters with flanged PN16 connections, PN25, PN40, ANSI 150, 300.600.
- For horizontal or vertical pipelines with 2 x DN straight lengths
- Rangeability 1:20, Meters read in cubic metres, index can be head rotated through 360 deg

## Technical Data

Model	DN mm	Minimum Flow Rate m <sup>3</sup> /h	Maximum Flow Rate m <sup>3</sup> /h	Length	Interface
CGT/50GXX	50	3	100	150	Pulse
CGT/80GXXX	80	8	400	240	Pulse
CGT/100GXXX	100	13	650	300	Pulse
CGT/150GXXX	150	32	1600	450	Pulse
CGT/200GXXX	200	80	2500	600	Pulse

## Features

- Pressure rating: PN10 ÷ PN110 & ANSI150 ÷ ANSI600
- Nominal diameter: DN50 up to DN400
- Meter bodies: ductile cast iron or steel
- Flow: 6.5 to 10 000 m<sup>3</sup>/h
- Rangeability: 1:20 min at atmospheric pressure (increased rangeability on request)
- Upstream pipe: minimum 2 x DN
- Temperature range:  
gas temperature -20°C to +60°C  
ambient temperature -25°C to +70°C
- Operating position: horizontal or vertical
- Measurement accuracy according to EN12261 standard: 0.2Q<sub>max</sub> ÷ Q<sub>max</sub> < ±1%  
Q<sub>min</sub> ÷ 0.2Q<sub>max</sub> < ±2%  
improved accuracy on request
- Approvals:
  - MID
  - PED
  - ATEX
- Traceability to PTB standards

## Outputs

- Up to 10 transmitters for DN100-400
- Up to 8 transmitters for DN50-80
- LFK – low frequency reed contact pulse sensor
- LFI – low frequency inductive pulse sensor (NAMUR)
- HF1, HF2 – inductive pulse sensors in the index head (NAMUR)
- HF3, HF4 – inductive pulse sensors over the turbine wheel (NAMUR)
- HF5, HF6 – inductive pulse sensor over the reference wheel (NAMUR)
- AFK – anti-fraud reed contact
- Electrical outputs – Amphenol TUCHEL
- Index housing made of aluminium what perfectly protects index head against accidental damages
- Index housing may be provided with two separate sockets
- 2 pressure measurement taps as standard
- 2 temperature measurement taps (thermowells on request)

## Basic metrological parameters

DN Nominal Diameter	G Gas Meter Size	Q <sub>max</sub> Maximum Flow	Q <sub>min</sub> Minimum Flow at Rangeability		LF Transmitter Constant	HF1, HF2 Transmitter Constant (approximate)	HF3 - HF6 Transmitter Constant (approximate)
			1:20	1:30			
-	-	m <sup>3</sup> /h	[m <sup>3</sup> /h]	[m <sup>3</sup> /h]	[imp./m <sup>3</sup> ]	[imp./m <sup>3</sup> ]	[imp./m <sup>3</sup> ]
DN 50	G 65	100	5	-	10	2610	94829
DN 80	G 100	160	8	-	1	742	26974
	G 160	250	13	8	1	742	26974
	G 250	400	20	13	1	470	17059
DN 100	G 160	250	13	-	1	692	16782
	G 250	400	20	13	1	692	16782
	G 400	650	32	20	1	401	9719
DN 150	G 400	650	32	20	1	227	6873
	G 650	1000	50	32	1	227	6873
	G 1000	1600	80	50	0.1	129	3910
DN 200	G 650	1000	50	32	1	114	3113
	G 1000	1600	80	50	0.1	116	3167
	G 1600	2500	130	80	0.1	67	2025
DN 250	G 1000	1600	80	50	0.1	58	2111
	G 1600	2500	130	80	0.1	58	2111
	G 2500	4000	200	130	0.1	34	1223
DN 300	G 1600	2500	130	80	0.1	32	1181
	G 2500	4000	200	130	0.1	32	1181
	G 4000	6500	320	200	0.1	19	680
DN 400	G 2500	4000	200	130	0.1	13	444
	G 4000	6500	320	200	0.1	13	444
	G 6500	10000	500	320	0.1	7.0	285

## Pressure Loss

Pressure drop during the gas flow through the meter according to EN12261 is determined for air at atmospheric conditions. To calculate pressure drop at higher pressures, the following formula may be used:

$$\Delta p_1 = \left(\frac{\rho_a}{\rho}\right) \cdot \left(\frac{p + p_s}{p}\right) \cdot \Delta p$$

Definitions:

- Δp<sub>1</sub> - pressure loss at p
- Δp - pressure loss from the diagram below
- p - gauge pressure [bar]
- ρ - standard density of gas [kg/m<sup>3</sup>]
- ρ<sub>a</sub> - standard density of air 1,2 kg/m<sup>3</sup>
- p<sub>s</sub> - base pressure (1.01325 bar)

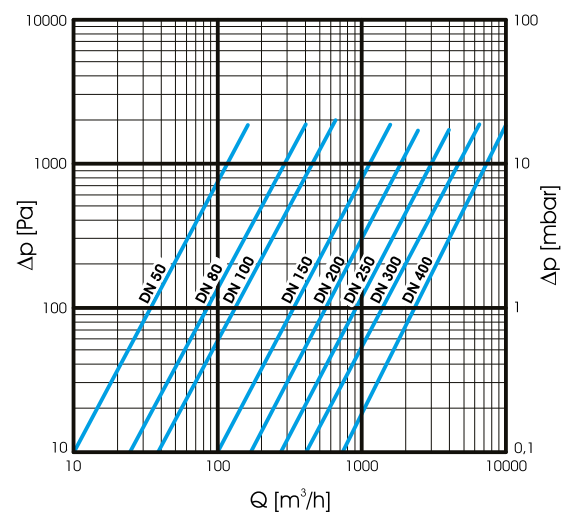

## Dimensions and weight

Overall dimensions and weights of CGT turbine gas meters.

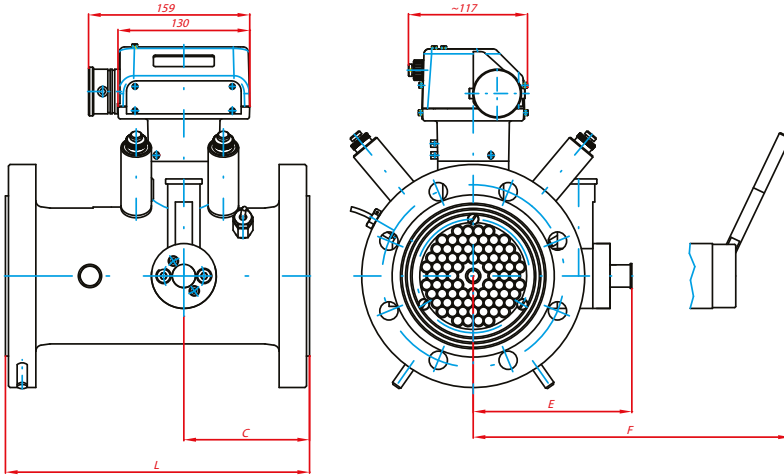

DN	L	C	E, F*	Pressure/flanges		Weight	
				ANSI	PN	Ductile iron	Steel
mm	mm	mm	mm	-	-	kg	kg
50	150	150	150	-	16	8,5	11
				150	20	9,5	10
			226	300	50	-	11,5
				-	64	-	14
80	240	95	146	600	110	-	14
				-	16	20	25
			222	150	20	19,5	24,5
				300	50	-	27,5
100	300	124	157	-	64	-	28
				600	110	-	32
			223	-	16	25	33,5
				150	20	26,5	34,4
150	450	180	185	300	50	-	43
				-	64	-	40
			261	600	110	-	56
				-	16	48	62,5
200	600	240	202	150	20	-	62,5
				300	50	-	80,5
			282	-	64	-	84
				600	110	-	106
250	750	330	232	-	16	-	80
				150	20	-	86
			308	300	50	-	116
				-	64	-	128
300	900	350	258	600	110	-	163
				-	16	-	142
			345	150	20	-	147
				300	50	-	190
400	1200	400	387	-	64	-	206
				600	110	-	271
			-	-	16	-	215
				150	20	-	235
-	-	-	387	300	50	-	290
				-	64	-	300
			-	600	110	-	360
				-	16	-	350
-	-	-	387	150	20	-	390
				300	50	-	480
			-	-	64	-	490
				600	110	-	580

### Accessories

✓ Thermowells



✓ Oil pumps

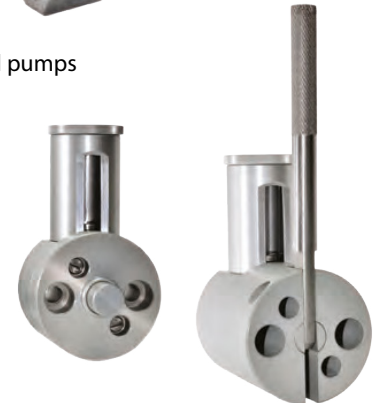

✓ 3-way valve

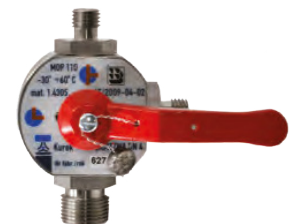

✓ Sprinkle flow straightener



✓ HF pulse transmitters

