



# HYDROSONIS-ULC

Compact ultrasonic thermal energy meter

Ultrasonic thermal energy meter designed to measure heating and cooling. It can be used for commercial metering of energy consumption for local heating systems: in dwelling houses, office buildings, energy plants and similar applications.

- Ultrasonic principle used for flow measurement
- Heating and cooling energy accumulated in separate registers
- Compact and removable electronic unit
- 24 monthly values including mid month values
- All installation possible without any restriction
- Available with M-Bus or M-BUS wireless output communication interface.

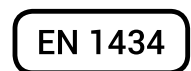

## TECHNICAL FEATURES

Protection class	IP54
Accuracy class	2 – 3 (EN 1434)
Energy units	KWh / MWh or MJ / GJ
Interface type	7-digit LCD screen
Cable length	1.5 m
Storage temperature	-20 – 60°C
Temperature range	5 – 105°C
Ambient temperature	5 – 55°C
Temperature difference	3 K – 80 K
Power supply	Battery (11 years maximum lifetime)
Data Logger features	Storage for 24 monthly values including mid-month values

## DIMENSIONS

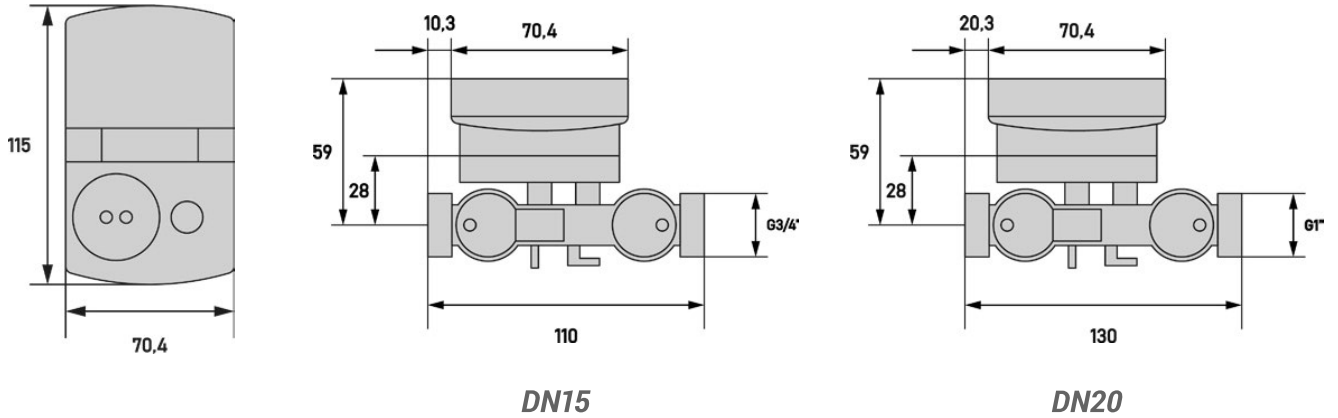

## TECHNICAL DATA

	DN	15	15	15
Nominal flow rate Qp	m <sup>3</sup> /h	0.6	1.5	2.5
Maximum flow rate Qs	m <sup>3</sup> /h	1.2	3.0	5.0
Minimum flow rate Qi	m <sup>3</sup> /h	0.006	0.015	0.025
Operating limit	l/h	1.2	3	5
Length	mm	110	110	130
Pressure loss at Qp	mbar	75	135	135
Threaded connection		G3/4"	G3/4"	G1"

Threading EN ISO 228-1:2003 Flange ISO 7005-2 / EN 1092-2 PN16

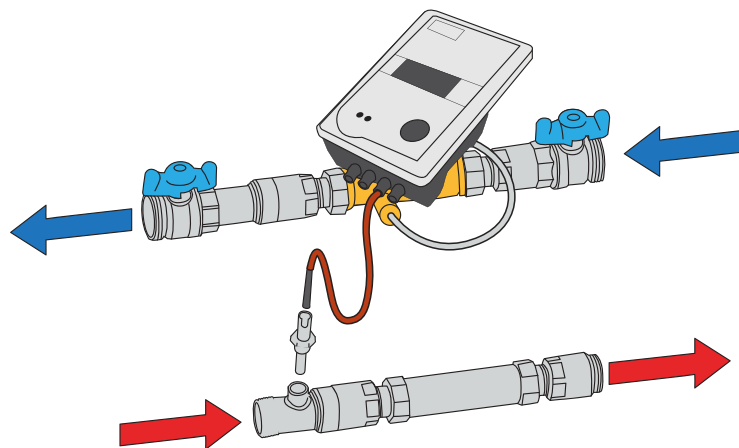

Standard version for installation on the return pipe.  
Version for installation on the flow pipe available upon request.

# DESIGNING, PRODUCING AND DISTRIBUTING SOLUTIONS FOR OVER 25 YEARS

B METERS is an Italian company that has been designing, producing and distributing instruments and solutions for measuring the consumption of water and thermal energy used for heating and cooling, for over 25 years.

The yearly production currently exceeds 2M units, putting B METERS in a leading position both at national and European level.

The product range includes turbine (velocity) type single and multi-jet water meters with mechanical or magnetic transmission, Woltmann meters, irrigation meters, flow meters, thermal energy meters and heat cost allocators with direct reading, or complete with integrated modules for the remote transmission of the consumption data.



EN 1434

EN 834

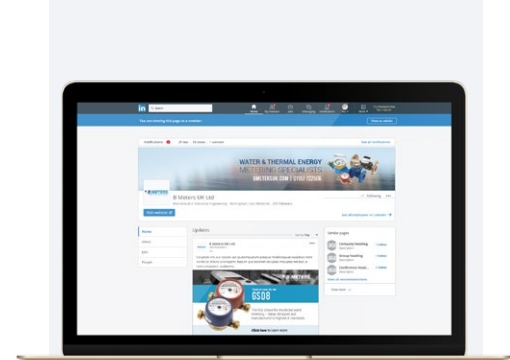

**FOLLOW BMETERS ON LINKEDIN,  
KEEP UP-TO-DATE WITH ALL  
LATEST NEWS AND PRODUCT  
INFORMATION**

## THE BMETERS RANGE



**WATER METERS**



**THERMAL ENERGY METERS**



**READING SYSTEMS**



**M-BUS SOLUTIONS**